

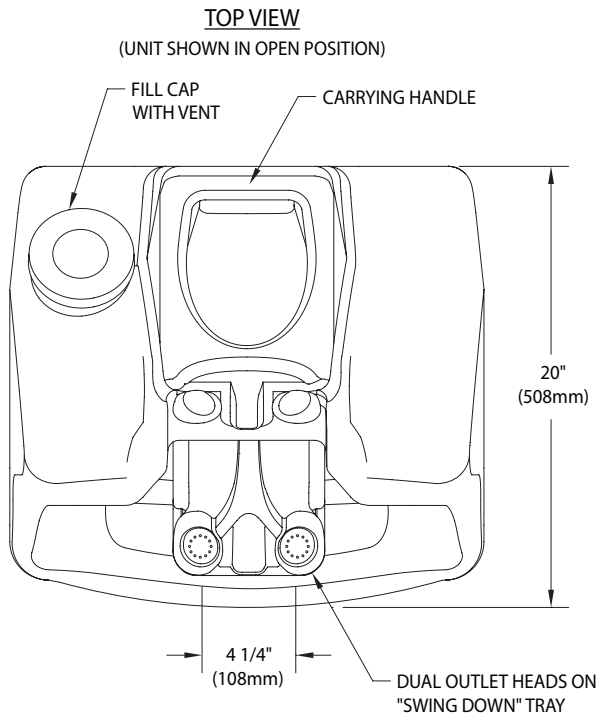

### □ G1540 AquaGuard Gravity-Flow Portable Eyewash, 16 Gallon



**NOTES:**

1. UNIT IS FURNISHED WITH WALL MOUNTING BRACKET AND 8 OZ BOTTLE OF BACTERIOSTATIC ADDITIVE TO PRESERVE WATER.
2. WALL BRACKET MOUNTING HOLES ARE POSITIONED 1-7/16" ABOVE THE UNIT.
3. UNIT SHOULD BE INSTALLED SUCH THAT WATER FLOW PATTERN IS POSITIONED BETWEEN 33" AND 53" ABOVE FLOOR.
4. UNIT WEIGHS 13 LBS EMPTY, 158 LBS FULL.

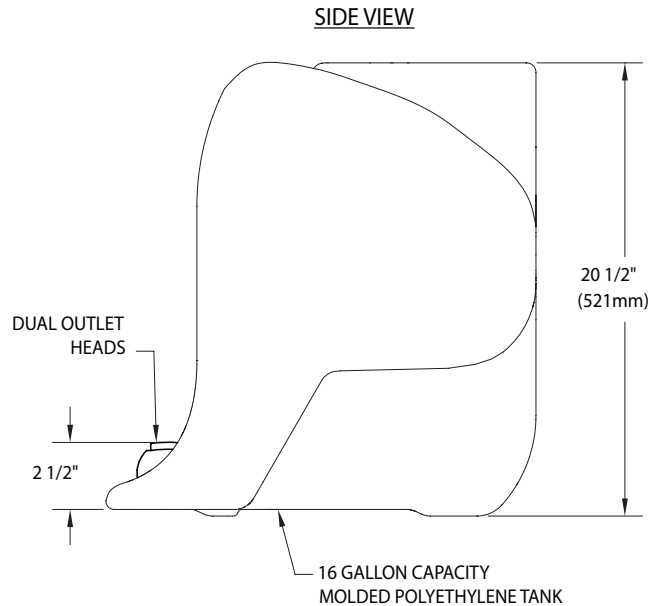
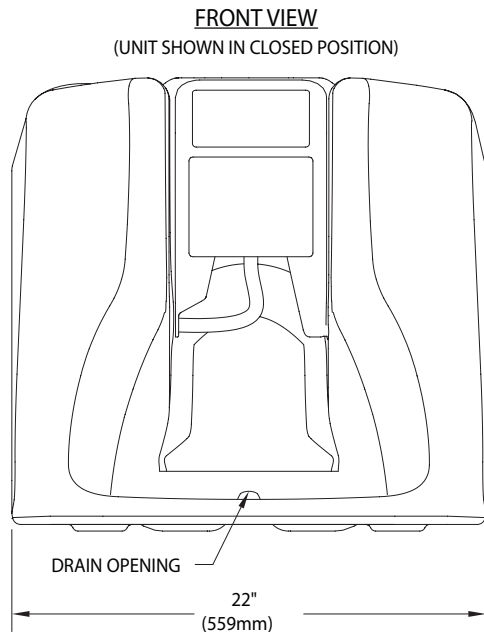
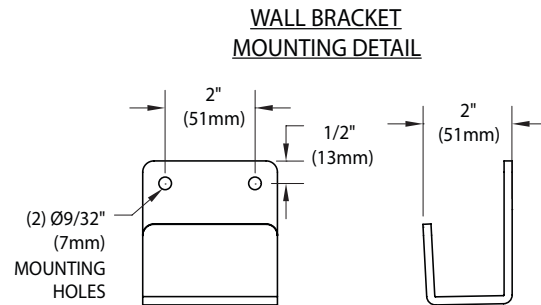

THIS SPACE FOR ARCHITECT/ENGINEER APPROVAL

Due to continuing product improvement, the information contained in this document is subject to change without notice. All dimensions are  $\pm 1/4"$  (6mm). rev. 0817

